

Fig.400 Straight Through Sight Flow Indicator with Spinner

Flow Indicators are used as a visual aid to process operations and plant protection. They provide windows into pipelines, enabling the user to see immediately if flow is taking place and to observe colour and condition of the flow.

FEATURES & BENEFITS

- Compact Sight Flow Indicators are used in plant room application to show coolant or lubrication flows to pumps, compressors and engines. This enables the user to view flow, presence and the condition of a liquid, gas or condensate.
- The Fig. 400 is able to be positioned in any orientation enabling more flexibility when installing.
- The high sensitivity of the spinner (6) enables indication of flow as low as 0.7l/s (water).
- Available in both Gunmetal or Stainless Steel bodies (1) giving the user greater options of flow medium.
- The Nitrile seals (4) and Nylon spinner (6) give excellent chemical resistance which is further enhanced in the stainless steel version by the use of Borosilicate glass (3) as standard.

For product application please refer to pages 30 and 31.



Fig.400 Stainless Steel



Fig.400 Gunmetal

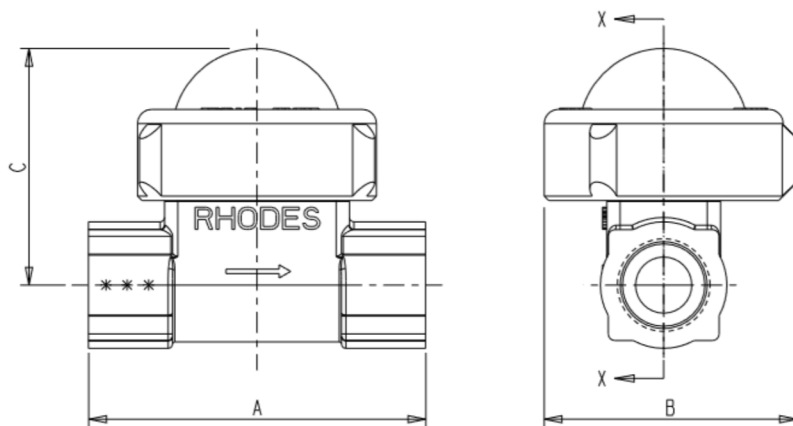

DIMENSIONS

Nominal Bore Size	Length A	Maximum Width B	Maximum Height from Centre C	Weight (kg)	Flowrate (l/h, water) Min	Flowrate (l/h, water) Max
DN8	76	57	55	0.5	30	200
DN10	76	57	55	0.5	50	450
DN15	76	57	55	0.6	60	600
DN20	83	57	58	0.6	120	1600
DN25	89	70	68	1.1	300	1600

Every effort has been made to ensure that the information contained in this publication is accurate at the time of publishing. Rhodes assumes no responsibility or liability for typographical errors or omissions or for any misinterpretation of the information within the publication and reserves the right to change without notice.

MATERIALS OF CONSTRUCTION

ITEM NO.	DESCRIPTION	BODY MATERIAL	MATERIAL	QTY
1	Body (options)	Gunmetal	BS EN 1982 CB491K	1
		Stainless Steel	ASTM A351 CF8M	
2	Cover Ring	Gunmetal	Brass BS2872 CZ122	1
		Stainless Steel	Nickel Plated Brass BS2872 CZ122	
3	Glass Dome	Gunmetal	Soda Lime	1
		Stainless Steel	Borosilicate	
4	Gaskets	Nitrile O Ring BS128		2
5	Spinner Mounting Pin	Stainless Steel 316		1
6	Spinner	Glass Filled Nylon		1

MAXIMUM RATINGS

Gunmetal	Stainless Steel
Pressure 7 Barg	Pressure 16 Barg
Temperature 100°C	Temperature 100°C

END CONNECTIONS

SCREWED

- BSP Taper Female 'Rc' BS EN 10226
- BSP Parallel Female 'Rp' BS EN 10226
- BSP Parallel Female 'G' ISO 228
- NPT Female

N.B. Fig. 400 is not available with flanged connections.

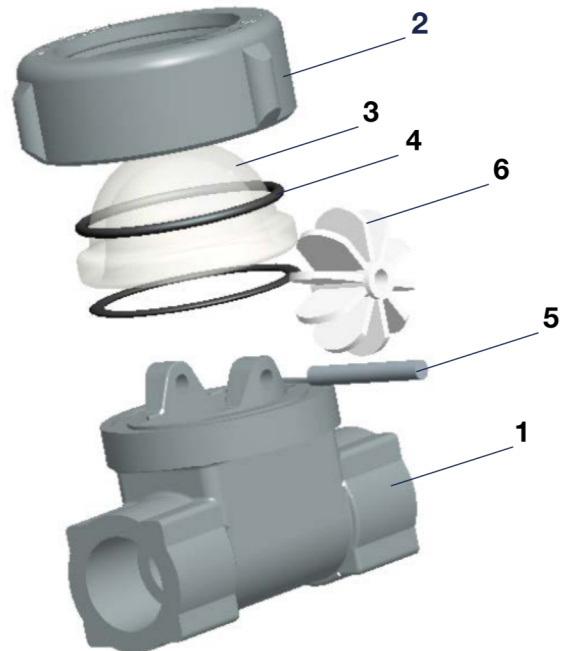

APPROVALS



FM00311 ISO 9001



ISO 14001 Reg No. EMS 78657

Every effort has been made to ensure that the information contained in this publication is accurate at the time of publishing. Rhodes assumes no responsibility or liability for typographical errors or omissions or for any misinterpretation of the information within the publication and reserves the right to change without notice.