



Downstream pressure reducer-stabilizer in stainless steel - Mod. VRCD FF

The CSA direct acting pressure reducing valve Mod. VRCD FF reduces and stabilizes the downstream pressure to a constant value, regardless of flow rate and upstream pressure variations. It can be used for water, air and fluids in general with a maximum working pressure of 64 bar.



Technical features and benefits

- Entirely manufactured in stainless steel machined from a solid bar.
- Upstream and downstream pressure balanced, to stabilize the downstream pressure to a pre-set (and adjustable) value regardless of upstream pressure variations without creating unwanted upsurges.
- Innovative self cleaning piston technology (patent pending) to improve performances reducing maintenance operations.
- Mobile block composed of stainless steel internals obtained by CNC to ensure the maximum accuracy and sliding precision, this is to avoid friction and unexpected leakage.
- Excellent resistance to cavitation and aggressive environments thanks to the design and the use of gaskets in special materials.
- Wide flow range and downstream pressure regulation values with long lasting performances compared to other solution in brass or different materials.

Applications

- Water distribution systems for high pressure ratio.
- Buildings and civil installations whenever stainless steel is required or advised for project aspects.
- Demineralized water and bottling plants.
- Industry and cooling systems.
- Mining and refineries.

Operating principle

The operating principle of VRCD FF, upstream pressure balanced, is based on a piston sliding into two rings of different diameters. These rings form a watertight chamber, also known as the compensation chamber, which is necessary for the accuracy and stability of the valve.



Valve normally open

Without any pressure the VRCD FF is a normally open valve, where the piston is kept pushed down by the force of the spring located in the cover.



Valve fully open

During working conditions, should the downstream pressure drop below the valve's set point obtained by the compression of the spring, the VRCD FF will open completely allowing the full passage.

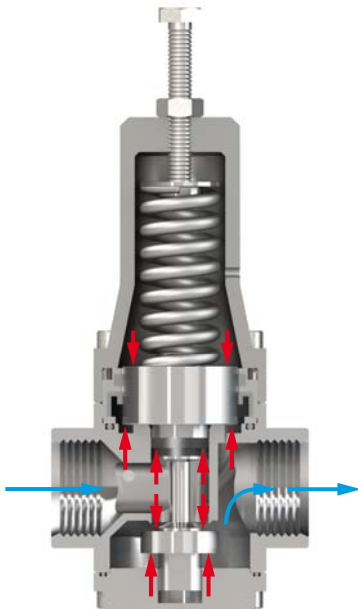

Valve modulating

Should the downstream pressure rise above the valve's set point the resultant of the force obtained by the downstream pressure acting on the mobile block and the compensation chamber against the spring pushing downwards, will move the obturator producing the required head loss to modulate and stabilize the downstream pressure.

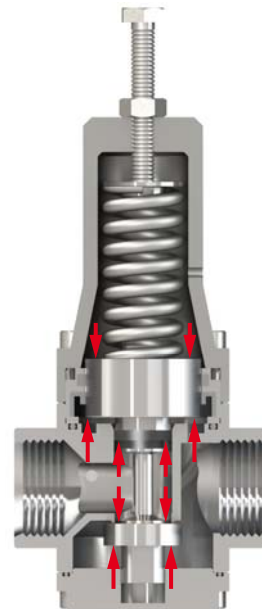

Valve fully closed (static conditions)

Should the water supply be interrupted from downstream the system will go in static conditions, the VRCD FF will maintain and stabilize the required pressure even with no flow thanks to the pressure balanced technology and compensation chamber.

Technical data

Thread (inches)	1/2"	1"	1" 1/2	2"
Kv (m ³ /h)/bar	2,9	7,2	10,8	21

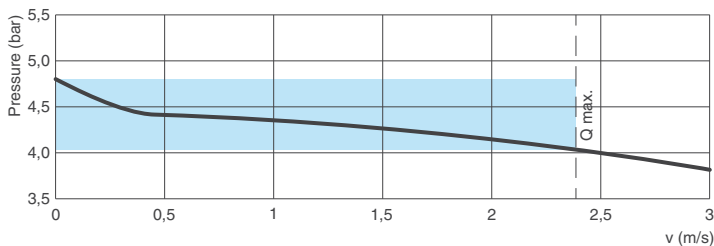
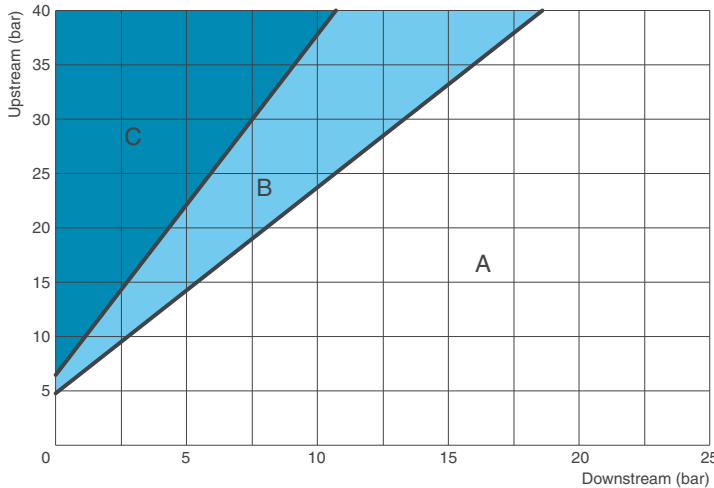

Working conditions

Treated water with a maximum temperature of 70°C (120°C on request).

Upstream pressure (inlet): maximum 40/64 bar.

Higher downstream pressure values on request.

Recommended flow rate

Thread (inches)	1/2"	1"	1" 1/2	2"
Flow rate min. (l/s)	0,02	0,05	0,11	0,30
Flow rate max. (l/s)	0,35	0,98	2,20	4,45
Exceptional (l/s)	0,39	1,50	2,80	6,90

Springs pressure ranges

Thread (inches)	1/2"	1"	1" 1/2	2"
Spring pressure (bar)	1,5-10	1,5-10	1,5-7	1,5-6
	2-20	2-20	2-15	5-12

Weights and dimensions

Thread inches	A mm	B mm	C mm	D mm	Weight Kg
1/2"	53	- -	108	25	1,0
1"	90	CH 41	170	45	2,1
1" 1/2	110	CH 55	205	50	2,8
2"	152	CH 70	290	60	5,9

Values are approximate, consult CSA service for more details.

Head loss coefficient

Kv coefficient representing the flow rate which is flowing through the valve fully open producing a head loss of 1 bar.

Cavitation chart

- A: Recommended working conditions;
- B: Incipient cavitation;
- C: Damage cavitation.

Ensure that the working point, obtained connecting upstream (y axis) and downstream (x axis) pressure conditions, falls on the A zone with the smallest valve to meet the required flow.

The chart is to be used for valves modulating with an opening percentage between 35-40% at standard water temperature and elevation below 300 m. For continuous pressure reduction the maximum allowed Δp shall not exceed 24 bar, for higher values contact CSA assistance.

Reduced pressure falloff

The plot is showing the reduced pressure falloff that occurs through the valve when the flow increases. Ensure that the operating conditions fall on the area depicted in blue for the recommended fluid flow velocity through the valve.

Standard

Certified and tested in compliance with EN 1074/5.

Threaded BSP connections.

Variations on the thread available on request.

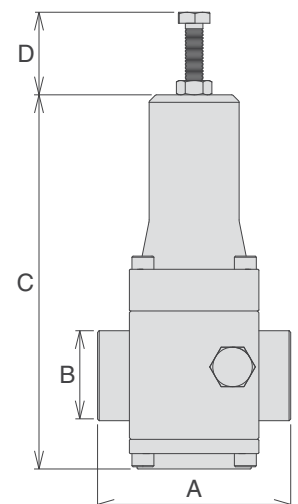

Technical details

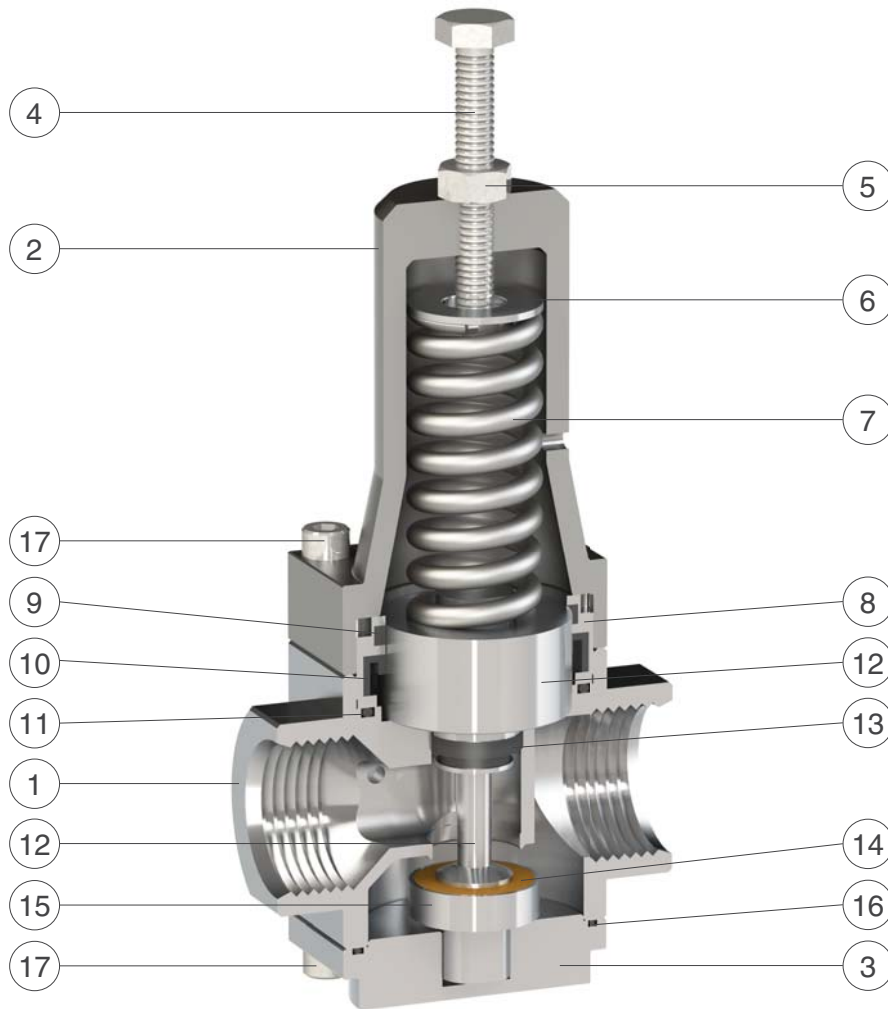

N.	Component	Standard material	Optional
1	Body	s.s. AISI 303 (1"-1" 1/2), AISI 304 (1/2"-2")	stainless steel AISI 316
2	Cap	nickel-plated aluminium S11	stainless steel AISI 316
3	Driving tap	s.s. AISI 303 (1"-1" 1/2), AISI 304 (1/2"-2")	stainless steel AISI 316
4	Driving screw	stainless steel AISI 304	stainless steel AISI 316
5	Nut	stainless steel AISI 304	stainless steel AISI 316
6	Spring guide	stainless steel AISI 304	stainless steel AISI 316
7	Spring	s.s. AISI 302 (painted steel 52SiCrNi5 for 2")	
8	Main bush	stainless steel AISI 304	stainless steel AISI 316
9	Sliding ring	PTFE	
10	Upper gasket	NBR	EPDM/Viton
11	O-ring	NBR	EPDM/Viton
12	Piston	stainless steel AISI 303	stainless steel AISI 316
13	Lower gasket	NBR	EPDM/Viton
14	Plane gasket	polyurethane	
15	Obturator guide	stainless steel AISI 303	stainless steel AISI 316
16	Tap O-ring	NBR	EPDM/Viton
17	Screws	stainless steel AISI 304	stainless steel AISI 316

The list of materials and components is subject to changes without notice.