

→ Series 681



■ SUITABLE FOR

Liquids	neutral and non-neutral	
Air, gases and vapours	neutral and non-neutral	
Potable water cold	up to 40°C	
Potable water hot	up to 95°C	

■ EXAMPLES OF USE

For the protection of:

- domestic water supply systems
- commercial and industrial plants

against too high supply pressure.

Pressure reducers are used, if within a piping system despite of varying pressures on the inlet side a certain pressure must not be exceeded on the outlet side.

- potable water supply according to DIN 1988
- process water supply in industrial-and building technology
- snow-making equipment
- fire-fighting equipment and sprinkler systems
- shipbuilding industry and offshore plants

■ APPROVALS

DIN-DVGW type examination (up to 80°C)	
Type approval ACS	
Type approval WRAS (up to 85°C)	
Type approval PZH	
TR ZU 032/2013 - TR ZU 010/2011	
<b>Requirements</b>	
DIN DVGW guidelines	DIN EN ISO 3822
DIN EN 1567	DGR 2014/68/EU
DIN 1988	
<b>Classification society</b>	
DNV	DNV
Lloyd's Register EMEA	LR EMEA
American Bureau of Shipping	ABS
Bureau Veritas	BV
Russian Maritime Register of Shipping	RMRS
Registro Italiano Navale	RINA



■ MATERIAL



■ SPECIFICATION



1/2" – 2"



-20°C to + 120°C



**Inlet pressure:**  
up to 40 bar  
**Outlet pressure:**  
0,5 to 15 bar  
depending on version

■ MATERIALS

Component	Material	DIN EN	ASME
Inlet body	Gunmetal	CC499K	CC499K
Outlet body	Gunmetal	CC499K	CC499K
Internal parts	Gunmetal	CC499K	CC499K
	Stainless Steel	1.4404	316 L
Spring	Spring steel with anti-rust protection	1.1200	ASTM A228
Strainer	Stainless Steel	1.4404	316 L

<b>m</b>	with diaphragm	High-quality, heat-resistant moulded elastomere, fabric-reinforced diaphragm. Adjustment by means of non-rising spindle. Insert with balanced single seat valve made of gunmetal.
----------	----------------	---

**Complete valve insert SP/HP (order code: 681 Insert-DN...-seal) available as replacement part** can be exchanged without removing the valve.

**Complete valve insert LP (order code: 681 LP Insert-DN...-seal) available as replacement part** can be exchanged without removing the valve.

Built-in dirt trap made of stainless steel.

Mesh size:	DN 15 to DN 32	0,60 mm
	DN 40 and DN 50	0,75 mm

#### ■ MEDIUM

<b>GF</b>	gaseous and liquid	for water, neutral and non-sticking liquids, compressed air and neutral gases; optionally with FPM elastomere seals for non-neutral media i.e. oils, fuels, oil-laden compressed air, etc. Not suitable with steam.
-----------	--------------------	---

#### ■ TYPE OF LIFTING MECHANISM

<b>0</b>	without lifting device
----------	------------------------

#### ■ OUTLET PRESSURE RANGES

<b>SP</b>	Standard version	Inlet pressure: up to 40 bar	Outlet pressure: from 1 to 8 bar
<b>HP</b>	High-pressure version	Inlet pressure: up to 40 bar	Outlet pressure: from 5 to 15 bar
<b>LP</b>	Low-pressure version	Inlet pressure: up to 25 bar	Outlet pressure: from 0,5 to 2 bar

#### ■ AVAILABLE NOMINAL DIAMETERS AND CONNECTION SIZES

Nominal diameter DN	15	20	25	32	40	50
Inlet	1/2" (15)	3/4" (20)	1" (25)	1 1/4" (32)	1 1/2" (40)	2" (50)
Outlet	1/2" (15)	3/4" (20)	1" (25)	1 1/4" (32)	1 1/2" (40)	2" (50)

#### ■ TYPE OF CONNECTION INLET / OUTLET THREADED CONNECTIONS

<b>BSP-Tm / BSP-Tm</b>	Standard threaded connections	Male thread BSP-T / Male thread BSP-T	DIN EN 10226, ISO 7-1 / DIN EN 10226, ISO 7-1
<b>f / f</b>	Version with female thread available in sizes DN15, DN20 and DN25	Female thread BSP-P / Female thread BSP-P	DIN EN ISO 228-1 / DIN EN ISO 228-1
<b>NPT-f / NPT-f</b>	Version with female thread available in sizes DN15, DN20 and DN25	Female thread NPT-f / Female thread NPT-f	ANSI B1.20.1 / ANSI B1.20.1

#### ■ SEALS

<b>EPDM</b>	Ethylene propylene diene	Elastomere moulded diaphragm and seals approvals according to drinking water directive	-20°C to +120°C (up to 8 bar outlet pressure) -20°C to +95°C (from 8 bar outlet pressure)
<b>FKM</b>	Fluorocarbon	Elastomere moulded diaphragm and seals	-10°C to +120°C (up to 8 bar outlet pressure) -10°C to +95°C (from 8 bar outlet pressure)

■ NOMINAL DIAMETERS, CONNECTIONS, INSTALLATION DIMENSIONS

Series 681: Connection, installation dimensions, ranges of adjustment								
Connection	DN	15	20	25	32	40	50	
Inlet DIN EN 10226	G1	1/2"	3/4"	1"	1 1/4"	1 1/2"	2"	
Outlet DIN EN 10226	G2	1/2"	3/4"	1"				
Inlet pressure SP, HP up to	bar	40	40	40	40	40	40	
Inlet pressure LP up to	bar	25	25	25	25	25	25	
Outlet pressure	bar	0,5 - 2	0,5 - 2	0,5 - 2	0,5 - 2	0,5 - 2	0,5 - 2	
		1 - 8	1 - 8	1 - 8	1 - 8	1 - 8	1 - 8	
		5 - 15	5 - 15	5 - 15	5 - 15	5 - 15	5 - 15	
Installation dimensions in mm	L	142	158	180	193	226	252	
	I	80	90	100	105	130	140	
	I1	85	95	105				
	H (H1)	102 (128 <sup>1</sup> )	102 (128 <sup>1</sup> )	130 (150 <sup>1</sup> )	130 (150 <sup>1</sup> )	165 (185 <sup>1</sup> )	165 (185 <sup>1</sup> )	
	H2 (H3)	124 (150 <sup>2</sup> )	124 (150 <sup>2</sup> )	161 (181 <sup>2</sup> )	161 (181 <sup>2</sup> )	198 (218 <sup>2</sup> )	198 (218 <sup>2</sup> )	
	h	33	33	45	45	70	70	
	SW1	30	37	46	52	65	75	
	SW2	28	35	43				
	Pressure gauge connection	G3	1/4" axial	1/4" axial	1/4" axial	1/4" axial	1/4" axial	1/4" axial
	Outlet pressure							
Weight	kg	1,2 (1,5 <sup>1</sup> )	1,3 (1,6 <sup>1</sup> )	2,4 (2,9 <sup>1</sup> )	2,6 (3,1 <sup>1</sup> )	5,5 (6,2 <sup>1</sup> )	6,0 (6,7 <sup>1</sup> )	
Coefficient of flow $K_{vs}^3$	m <sup>3</sup> /h	3	3,5	6,7	7,6	12,5	15	

<sup>1</sup>for type 681mGF0-LP

<sup>2</sup>for type 681mGF0-LP S15

<sup>3</sup>The  $K_{vs}$  value was determined according to DIN EN 60534-2-3. Instructions on how to determine size and capacity are to be found under section 2.

■ MAIN DIMENSIONS, INSTALLATION DIMENSIONS

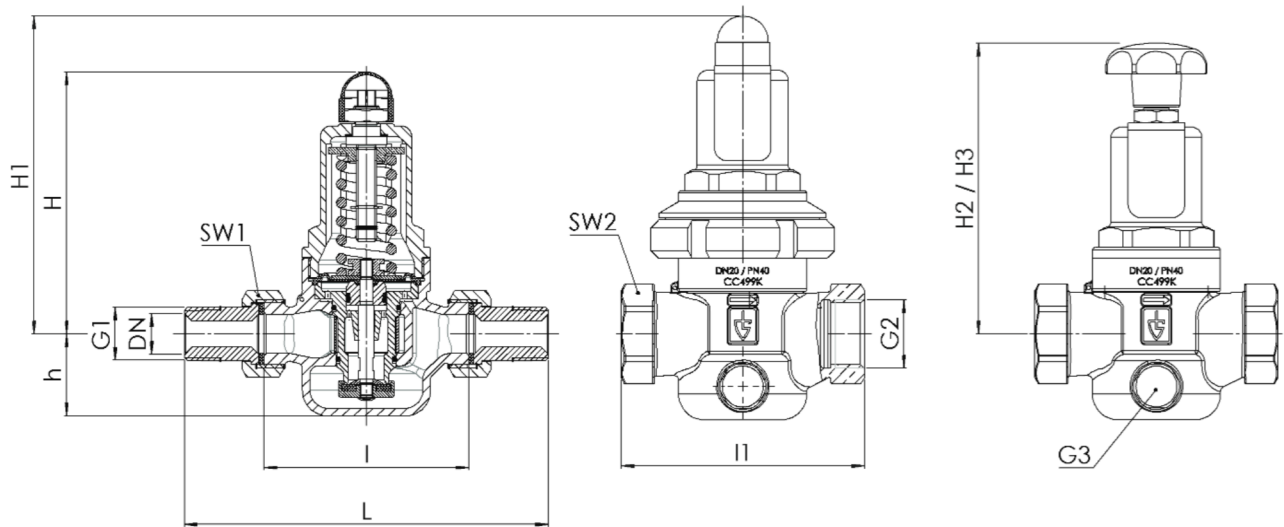

Series	Valve version	Medium	Lifting device	Outlet pressure	Nominal diameter DN	Connection type		Connection size		Seal	Options	Optional: fixed setting	Quantity
						Inlet	Outlet	Inlet	Outlet				
681	m	GF	0	SP	20	BSP-T m	BSP-T m	20	20	EPDM	Manometer 36		8
681	m	GF	0	SP	15	f	f	15	15	EPDM			4
681	m	GF	0										
681	m	GF	0										

### ■ PROPERTIES

S15	Hand wheel (plastic) for tool-free setting of setpressure <sup>1</sup>	<input type="checkbox"/>	<input type="checkbox"/>
S17	Supply with manometers suitable for the valve finish	<input type="checkbox"/>	<input type="checkbox"/>
S71	Preliminary setup for protection against manipulation of the preset pressure (seal)	<input type="checkbox"/>	<input type="checkbox"/>

<sup>1</sup>For nominal diameters DN15 to DN50 outlet pressure ranges LP and SP

### ■ OPTIONS

GOX	Especially for gaseous O2 applications by employment of specific materials including oil- and grease free production process	<input type="checkbox"/>	P03	Galvanically nickel-plated finish	<input type="checkbox"/>
P01	Oil- and grease-free production	<input type="checkbox"/>	FE	Setting and sealing	<input type="checkbox"/>
P02	Chemically nickel-plated finish	<input type="checkbox"/>			<input type="checkbox"/>

### ■ CERTIFICATES / APPROVALS

C01	Factory certificate acc. DIN EN 10204 2.2 (WKZ 2.2)	<input type="checkbox"/>	C05	Sealing material Manufacturer certification (FDA, USP 3, 3-A, ...), Please indicate description of certificate: _____	<input type="checkbox"/>
C02	Test certificate acc. DIN EN 10204 3.1 (WPZ 3.1)	<input type="checkbox"/>	C06	ATEX evaluation acc. to 2014/34/EU	<input type="checkbox"/>
C03	Material test certificate acc. DIN EN 10204 3.1 (MPZ 3.1) (pressure retaining part)	<input type="checkbox"/>	C10	Certificate of oil- and grease free production	<input type="checkbox"/>
C04	TÜV/DEKRA individual inspection acc. EN 10204 3.2 (TÜV/DEKRA-APZ)	<input type="checkbox"/>	C11	Certification of the production process especially for gaseous oxygen applications by employment of specific materials	<input type="checkbox"/>

### ■ ADMISSIONS / ACCREDITATIONS

AA1	EC Type examination acc. to Directive 2014/68/EU	<input checked="" type="checkbox"/>	AK1	Det Norske Veritas (DNV) type approval	<input type="checkbox"/>
AA4	EAC - certificate/declaration with passport for the valve and laser marking of the valve	<input type="checkbox"/>	AK2	Lloyd's Register (LR) type approval	<input type="checkbox"/>
AB1	Deutscher Verein des Gas- und Wasserfaches, DVGW type approval	<input type="checkbox"/>	AK3	American Bureau of Shipping (ABS) type approval	<input type="checkbox"/>
AB2	Water regulations and advisory scheme WRAS type approval	<input type="checkbox"/>	AK4	Bureau Veritas (BV) type approval	<input type="checkbox"/>
AB3	Attestation de Conformité Sanitaire, ACS type approval	<input type="checkbox"/>	AK5	Russian Maritime Register of Shipping (RMRS) type approval	<input type="checkbox"/>
AB4	Stiftelsen for industriell og teknisk forskning, SINTEF type approval	<input type="checkbox"/>	AK6	Registro Italiano Navale (RINA) type approval	<input type="checkbox"/>
		<input type="checkbox"/>	AL	Individual inspection by notified body inspector – (body to be indicated): _____	<input type="checkbox"/>

### ■ ENQUIRY

Copy and send to: [order@goetze-armaturen.de](mailto:order@goetze-armaturen.de).

Order form easily to be found online under the section for each series.

Series 681:

Dimensioning by pressure loss on the outlet pressure side

**Flow chart water**

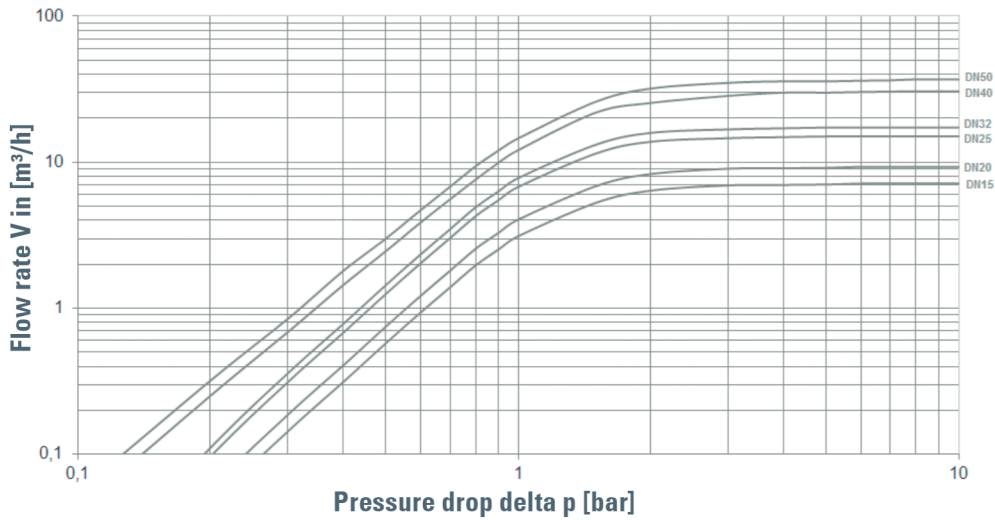

Dimensioning by flow velocity

**For liquids:**

With help of the chart you can determine the nominal diameter (DN) for a given flow volume V (m³/h). According to DVGW-guidelines (DIN 1988) a flow velocity of 2 m/s in domestic water supply systems should not be exceeded.

**For compressed air and other gaseous media:**

The usual flow velocity for compressed air is 10 - 20 m/s. For gaseous media the flow volume V should always be shown in actual cubic meters/hour. If the flow volume is given in standard cubic meters, these should be converted into actual cubic meters before using the diagram.

$$V \text{ (m}^3\text{/h)} = \frac{V_{\text{Norm}} \text{ (Nm}^3\text{/h)}}{p_{\text{absolut}} \text{ (bar)}} = \frac{V_{\text{Norm}}}{p_{\text{u}} + 1}$$

Actual cubic meters are based on the prevailing pressure of the medium on the outlet side of the pressure reducer.

