

SAFOX® penstock

Nominal size DN 150 to 3000, for round openings, mounting with chemical anchor bolts

Whilst leakage on penstocks is usually caused by insufficient frame stability and frame distortion SAFOX® patented sealing system is not affected by those parameters as it is separated from the frame. Due to this separation SAFOX® perfectly seals to the mounting wall and sliding plate and is even able to level structural variations. The freely suspended sealing ring is self-adjusting and does not require any adjustment. The tight and vibration-free guiding of the plate about the whole stroke enables SAFOX® to get used for throttling purposes.

SAFOX® can be operated in intermediate positions. SAFOX® penstocks are non-drip leak proof under on-seating and off-seating pressure and withstand water heads up to 10 m wc. When required SAFOX® can be supplied to withstand higher water heads.

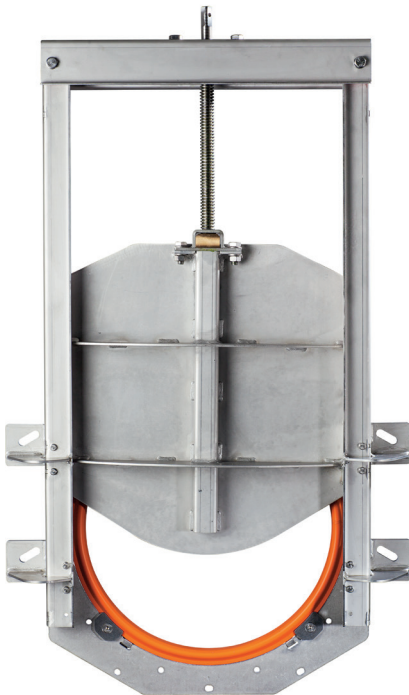

Materials

Frame:	Stainless steel SS304 or SS316Ti
Sliding plate:	Stainless steel SS304 or SS316Ti
Sealing:	EPDM, wastewater resistant or NRB
Stem:	Stainless steel SS304 or SS316Ti
Stem nut:	GC-CuSn 12, bronze, seawater resistant
Chem. anchor bolts:	Stainless steel S32304

Other materials available on request.

Sealing performance

- Patented sealing system separated from frame
- Easy exchangeable sealing without disassembly of penstock
- Leak-proof (non-drip) up to 10 m on-seating and off-seating heads (standard) in accordance with EN12266, Tab.A.5, leakage rate C, SAFOX® can be designed to withstand higher seating heads on request
- Pressure rates:
 - DN 150–300: 10 m wc
 - DN 400–800: 8 m wc
 - DN 900–1200: 7 m wc
 - Larger DN 1200: 6 m wc
 Also available for higher pressures
- Wastewater-resistant sealing material

Installation advantages

- Sealing is already installed
- No dowels in the bottom
- Quick and easy installation with few fixing brackets
- No additional adjustments necessary on the penstock
- Long holes in the fixing brackets

Operation advantages

- Applicable for throttling purposes in the standard version
- Minimal closing and opening torque
- Maintenance free
- Self-cleaning stem nut
- Durable operating reliability
- High process safety due to outstanding sealing performance

Corrosion resistance

- Maximum corrosion resistance due to stainless steel material, all acid cleaned and passivated in own pickling plant

Operation

- Operating key, hand wheel, electric or pneumatic actuator, gears and a wide range of extensions: see BÜSCH MAS programme

Customisations

- SAFOX® G: creating a planar passage on the channel bottom through gate
- SAFOX® F: for connection to flange

Accessories

- MAS Modular Actuating System packages: see BÜSCH MAS programme
- MOBITORQ Mobile Actuator: see brochure
- BEA BÜSCH Electric Actuator: see brochure
- Operating key: e.g. All-in-One operating key

Areas of application

- Municipal and industrial wastewater treatment plants
- Chemical industry
- Rain reservoirs
- Flood protection
- Power plants

SAFOX® penstock

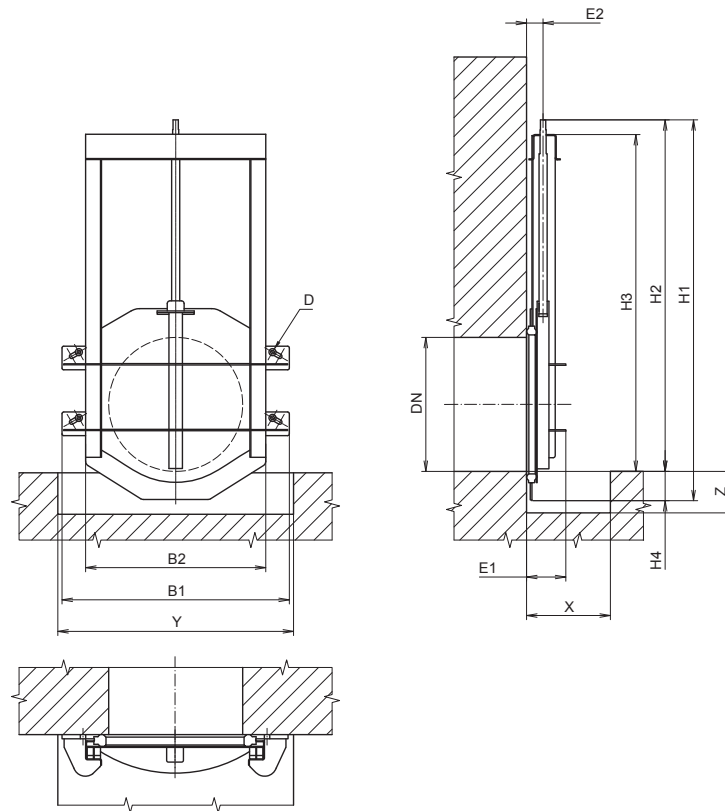

SAFOX® penstock

DN	150	200	250	300	400	500	600	700	800	900	1000	1200	1400	1500	1600	1800	2000	2200	2400	2600	2800	3000
B1	412	462	512	562	674	774	874	1070	1170	1304	1404	1604	2062	2162	2262	2462	2662	2862	3260	3460	3660	3860
B2	272	322	372	422	534	634	734	830	930	1064	1164	1364	1750	1850	1950	2150	2350	2550	2860	3060	3260	3460
E1	100	100	100	100	115	115	125	175	175	200	200	200	ca. 350	ca. 350	ca. 350	ca. 450	ca. 450	ca. 500	ca. 500	ca. 500	ca. 500	ca. 500
E2	48	48	48	48	48	48	48	68	68	68	68	68	100	100	100	120	120	140	167	167	167	167
H1	610	710	810	915	1127	1327	1527	1903	2103	2313	2513	2913	3644	3844	4044	4546	4966	5366	6315	6715	7115	7515
H2	535	635	735	840	1044	1244	1444	1782	1982	2192	2392	2792	3452	3652	3852	4354	4774	5174	6015	6415	6815	7215
H3	490	590	690	795	999	1199	1399	1722	1922	2132	2332	2732	3276	3476	3676	4133	4533	4933	5775	6175	6575	6975
H4	75	75	75	75	83	83	83	121	121	121	121	121	192	192	192	192	192	192	300	300	300	300
X min	200	200	200	200	200	200	200	250	250	250	250	250	450	450	450	550	550	600	ca. 800	ca. 800	ca. 800	ca. 800
Y min	455	505	555	605	720	820	920	1100	1200	1330	1430	1630	2162	2262	2362	2562	2762	2962	3460	3660	3860	4060
Z min	120	120	120	120	150	150	150	170	170	170	170	170	242	242	242	242	242	242	400	400	400	400
D	2 x Ø 13	2 x Ø 13	2 x Ø 13	2 x Ø 13	4 x Ø 13	4 x Ø 13	4 x Ø 13	4 x Ø 19	4 x Ø 19	6 x Ø 19	6 x Ø 19	6 x Ø 19	6 x Ø 25	6 x Ø 25	6 x Ø 25	10 x Ø 35	10 x Ø 35	10 x Ø 35	14 x Ø 35	14 x Ø 35	14 x Ø 35	14 x Ø 35
Turns/ Stroke	38	48	58	68	90	110	130	157	177	198	218	258	ca. 192	ca. 200	ca. 220	ca. 210	ca. 235	ca. 226	ca. 260	ca. 280	ca. 300	ca. 320

All dimensions in mm, other sizes available on request.



BÜSCH Technology GmbH

Neuburger Straße 26
90451 Nürnberg, Germany
E-Mail info@buesch.com
Tel. +49 (911) 46 254-0
Fax +49 (911) 46 254-70